

UNIFORM STATUTORY DECLARATION FORM FOR THE REGISTRATION OF FITTING DESIGNS

NEW BRUNSWICK
NUNAVUT

NOVA SCOTIA
YUKON

PRINCE EDWARD ISLAND
NORTHWEST TERRITORIES

NEWFOUNDLAND AND LABRADOR

MANUFACTURERS NAME: <u>Swagelok Company</u>	
MANUFACTURERS ADDRESS: <u>29500 Solon Road, Solon, Ohio 44139 USA</u>	
PLANT LOCATIONS: <u>Headquarters: 29500 Solon Road, Solon, Ohio 44139 USA (See Attachment A)</u>	
CATEGORY OF FITTINGS TO BE REGISTERED. CIRCLE ONE CATEGORY ONLY	
A Pipe fittings, including couplings, tees, elbows, Ys, plugs, unions, pipe caps, or reducers B Flanges: all flanges C Valves: all line valves D Expansion joints, flexible connections, and hose assemblies: all types E Strainers, filters, separators, and steam traps F Measuring devices, including pressure gauges, level gauges, sight glasses, levels, or pressure transmitters G Certified capacity-rated pressure relief devices acceptable as primary over pressure protection on boilers, pressure vessels, piping and fusible plugs H Pressure retaining components that do not fall into one of the above categories I Nuclear components: Class 1 <input type="checkbox"/> Class 2 <input type="checkbox"/> Class 3 <input type="checkbox"/> (Meeting AECB or ASME requirements)	TITLE OF THE STANDARD TO WHICH THE FITTING IS MADE: ASME B31.1 and ASME B31.3 (for unlisted components)
SHOW MANUFACTURERS NAME, TRADEMARK, OR LOGO AS IT WILL APPEAR ON THE PRODUCT	
Swagelok	TYPE OF CONSTRUCTION: FORGED <input type="checkbox"/> WELDED <input type="checkbox"/> WROUGHT <input checked="" type="checkbox"/> CAST <input type="checkbox"/> OTHER <input type="checkbox"/> Describe other:
LIST OF SUPPORTING DOCUMENTATION AND IDENTIFICATION OF THE ACTUAL ITEMS TO BE REGISTERED:	
<u>ISO 9001:2015 Certificate, Attachment A, Attachment B, Catalog Information and other Support Documents</u>	

DECLARATION:

I, Joel Feldman, Vice President, Engineering (see note 1) employed by Swagelok Company and being the person having full authority and responsibility for the quality of the end product do solemnly declare that the information contained in this form is true and to the best of my knowledge represents the product for which registration is sought. The dimensions, materials of construction, pressure temperature ratings, and identification markings are in accordance with the herein named standards. I further declare that the manufacture of these fittings is regulated by a Quality Control Program which extends to each plant where fabrication occurs in whole or in part and has been verified by BSI as being suitable for that purpose and I make this solemn declaration conscientiously believing it to be true, and knowing that it is of the same force and effect as if made under oath.

Signature of Declarer: [Signature]
 Declared before me at Solon, Ohio
 This 09th day of August AD 2018
 Commissioner of Oaths or Notary Public: (sign) [Signature]

USE THIS SPACE FOR THE
OFFICIAL SEAL

Jamie L. Ristes
 Resident Portage County
 Notary Public, State of Ohio
 My Commission Expires: 03/04/2019

This registration must be revalidated after ten (10) years from the date of acceptance. CRN: <u>0C20862.5</u> FID: <u>1214</u> Notes: 1. All fittings shall be registered in the name of the Manufacturer. 2. Each category shall be supported with two Statutory Declaration forms and one copy of supporting documentation. 3. The declaration shall be made by the person having full authority and responsibility for the quality of the end product. 4. Quality control programs shall be resubmitted for validation at a maximum interval of five (5) years.	NUNAVUT Boilers and Pressure Vessels Act REGISTERED CRN <u>DC 20862.5N</u> Date: <u>Jan 11, 2018</u> Signed: <u>[Signature]</u> Chief Inspector Territorial Registration Fee
---	---



Attachment B. Scope for Swagelok N, HN and 6DB Series Needle Valves (Category C)

This document represents the scope of the Swagelok N, HN and 6DB Series Needle Valves covered by this submission for CRN approval. The Swagelok N, HN and 6DB Series Needle Valves were designed and evaluated in accordance with ASME B31.1-2016 for unlisted components and ASME B31.3-2016 for unlisted components.

Summary Table

Product Description or Series	Main Pressure Bearing Component	Main Pressure Bearing Material (Standard)	Port Connections, Sizes*	Maximum Rated Pressure (psig)		Design Code of Construction		
				At ambient temperature	At maximum temperature			
3N	Body	316 SS (ASTM A479)	Female NPT 1/8", 1/4" Male NPT 1/4" Tube Socket Weld 1/4"	6000 @ 100°F	1715 @ 1200°F	ASME B31.1 (Unlisted Components) and ASME B31.3 (Unlisted Components)		
			Tube Fitting 1/4", 8MM Male VCR Fitting 1/4"	6000 @ 100°F	3030 @ 1000°F			
			Male VCO Fitting 1/4"	6000 @ 100°F	3870 @ 550°F			
		Alloy 400 (UNS N04400) (ASTM B164)	Tube Fitting 1/4" Female NPT 1/8", 1/4" Female NPT 1/8", 1/4" Male NPT 1/4" Tube Socket Weld 1/4" Male NPT 1/4" Tube Socket Weld 1/4" Male VCO Fitting 1/4"	5000 @ 100°F	3960 @ 500°F			
			Alloy 600 (UNS N06600) (ASTM B564, ASTM B166 or ASTM B168)	Female NPT 1/8", 1/4" Male NPT 1/4" Tube Socket Weld 1/4"	6000 @ 100°F		515 @ 1200°F	
				Tube Fitting 1/4" Male VCR Fitting 1/4" Male VCO Fitting 1/4"	6000 @ 100°F		1800 @ 1000°F 4860 @ 550°F	
		Alloy C-276 (UNS N10276) (ASTM B574 or ASTM B575)	Female NPT 1/8", 1/4" Male NPT 1/4" Tube Socket Weld 1/4"	6000 @ 100°F	1545 @ 1200°F			
			Tube Fitting 1/4" Male VCR Fitting 1/4"	6000 @ 100°F	3030 @ 1000°F			
			Male VCO Fitting 1/4"	6000 @ 100°F	5290 @ 550°F			
		6N	Body	316 SS (ASTM A479)	Female NPT 1/4", 3/8" Tube Socket Weld 3/8", 1/2" Pipe Socket Weld 1/4"		6000 @ 100°F	1715 @ 1200°F
					Tube Fitting 3/8", 1/2"		6000 @ 100°F	3030 @ 1000°F
					Male VCR Fitting 1/2"		4300 @ 100°F	2430 @ 1000°F
Alloy 400 (UNS N04400) (ASTM B164)	Male VCO Fitting 1/2"			6000 @ 100°F	3870 @ 550°F			
	Tube Fitting 3/8" Female NPT 1/4", 3/8" Tube Socket Weld 3/8", 1/2" Pipe Socket Weld 1/4" Male VCR Fitting 1/2" Male VCO Fitting 1/2"			5000 @ 100°F	3960 @ 500°F			
Tube Fitting 1/2"	4400 @ 100°F			3476 @ 500°F				

* Fractional port connection sizes shown. Equivalent metric size ranges are also in scope, and have the same pressure/temperature ratings

Product Description or Series	Main Pressure Bearing Component	Main Pressure Bearing Material (Standard)	Port Connections, Sizes*	Maximum Rated Pressure (psig)		Design Code of Construction
				At ambient temperature	At maximum temperature	
6N	Body	Alloy 600 (UNS N06600) (ASTM B564, ASTM B166 or ASTM B168)	Female NPT 1/4", 3/8" Tube Socket Weld 3/8", 1/2" Pipe Socket Weld 1/4"	6000 @ 100°F	515 @ 1200°F	ASME B31.1 (Unlisted Components) and ASME B31.3 (Unlisted Components)
			Tube Fitting 3/8"	6000 @ 100°F	1800 @ 1000°F	
			Male VCR Fitting 1/2"	4300 @ 100°F	1800 @ 1000°F	
			Tube Fitting 1/2"	5100 @ 100°F	1785 @ 1000°F	
			Male VCO Fitting 1/2"	6000 @ 100°F	4860 @ 550°F	
		Alloy C-276 (UNS N10276) (ASTM B574 or ASTM B575)	Female NPT 1/4", 3/8" Tube Socket Weld 3/8", 1/2" Pipe Socket Weld 1/4"	6000 @ 100°F	1545 @ 1200°F	
			Tube Fitting 3/8", 1/2"	6000 @ 100°F		
			Male VCR Fitting 1/2"	4300 @ 100°F	2430 @ 1000°F	
			Male VCO Fitting 1/2"	6000 @ 100°F	5290 @ 550°F	
			12N	Body	316 SS (ASTM A479)	
Tube Socket weld 3/4"	5900 @ 100°F	1715 @ 1200°F				
Tube Fitting 1/2"	6000 @ 100°F	3030 @ 1000°F				
Tube Fitting 3/4"	5800 @ 100°F	3030 @ 1000°F				
Tube Fitting 1"	4700 @ 100°F	3030 @ 1000°F				
Male VCR Fitting 1/2"	4300 @ 100°F	2430 @ 1000°F				
Male VCO Fitting 3/4"	6000 @ 100°F	3870 @ 550°F				
Alloy 400 (UNS N04400) (ASTM B164)	Female NPT 1/2", 3/4", 1" Male NPT 1/2", 3/4", 1" Tube Socket Weld 1/2", 3/4" Pipe Socket Weld 1/2"	5000 @ 100°F			3960 @ 500°F	
	Tube Fitting 3/4"	4600 @ 100°F			3634 @ 500°F	
	Tube Fitting 1"	4300 @ 100°F			3397 @ 500°F	
	Tube Fitting 1/2"	4400 @ 100°F	3476 @ 500°F			
THIS IS PART OF CRN 0020862-5 Technical Standards & Safety Authority Boilers & Pressure Vessels Safety Professionals		Alloy 600 (UNS N06600) (ASTM B564, ASTM B166 or ASTM B168)	Female NPT 1/2", 3/4", 1" Male NPT 1/2", 3/4", 1" Tube Socket Weld 1/2", 3/4" Pipe Socket Weld 1/2"	6000 @ 100°F	515 @ 1200°F	
			Tube Fitting 3/4", 1"	Not rated	Not rated	
			Tube Fitting 1/2"	5100 @ 100°F	1785 @ 1000°F	
		Alloy C-276 (UNS N10276) (ASTM B574 or ASTM B575)	Female NPT 1/2", 3/4", 1" Male NPT 1/2", 3/4", 1" Tube Socket Weld 1/2", 3/4" Pipe Socket Weld 1/2"	6000 @ 100°F	1545 @ 1200°F	
			Tube Fitting 3/4", 1"	Not rated	Not rated	
			Tube Fitting 1/2"	5100 @ 100°F	3030 @ 1000°F	
3HN	Body	316 SS (ASTM A479)	Female NPT 1/8", 1/4" Male NPT 1/4" Tube Socket Weld 1/4" Tube Fitting 1/4"	10000 @ 100°F 10000 @ 100°F	3085 @ 1200°F 5450 @ 1000°F	
6HN	Body	316 SS (ASTM A479)	Female NPT 1/4", 1/2" Male NPT 1/2" Tube Fitting 1/2"	10000 @ 100°F 6700 @ 100°F	3085 @ 1200°F 5092 @ 1000°F	

* Fractional port connection sizes shown. Equivalent metric size ranges are also in scope, and have the same pressure/temperature ratings

Product Description or Series	Main Pressure Bearing Component	Main Pressure Bearing Material (Standard)	Port Connections, Sizes*	Maximum Rated Pressure (psig)		Design Code of Construction
				At ambient temperature	At maximum temperature	
6DB	Body	316 SS (ASTM A479)	Female NPT 1/4", 3/8" Tube Socket Weld 3/8", 1/2" Pipe Socket Weld 1/4"	6000 @ 100°F	1715 @ 1200°F	ASME B31.1 (Unlisted Components) and ASME B31.3 (Unlisted Components)
			Tube Fitting 3/8", 1/2"	6000 @ 100°F	3030 @ 1000°F	

* Fractional port connection sizes shown. Equivalent metric size ranges are also in scope, and have the same pressure/temperature ratings.

Product Illustrations

N Series and HN Series Needle Valves

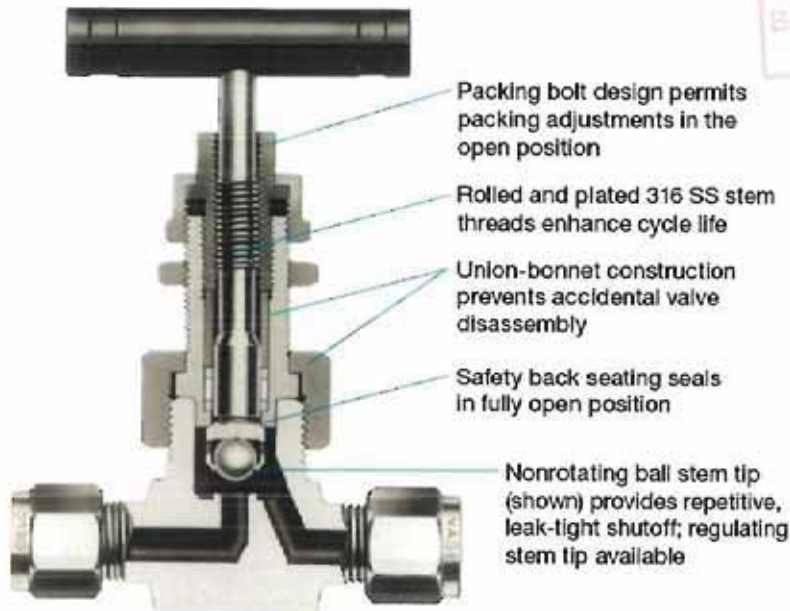

6DB Series Needle Valve



Configurations

Bodies are available in straight pattern and angle.

Product Options:

Some of the product options listed below affect the pressure-temperature ratings shown in the Summary Table, but in all cases the ratings are less than those shown in the Summary Table. All of the following options are within the scope of this registration:

Stem Packing Options

Ultra High Molecular Weight Polyethylene (UHMWPE)
Polyetheretherketone (PEEK)
Graphoil

Stem Designs

Regulating
PCTFE soft-seat regulating
PTFE soft-seat regulating

Additional options and non-pressure boundary alterations that do not affect pressure-temperature ratings may be made available within the scope of this registration. Examples of these would include handle options, actuator options, etc.

Quality System

The Swagelok Company quality system complies with the requirements of ISO 9001:2015. The Swagelok Company maintains BSI Certificate of Registration Number FM 01729, which applies to all locations listed on the Certificate. The N, HN and 6DB needle valve products are made at a Swagelok Company location in Solon, Ohio.

References

The product catalog does not represent the full scope of registration, but rather details some of the most common options.

- N Series and HN Series Needle Valve Catalog MS-01-168, Rev L
- 6DB Series Needle Valve Catalog MS-02-118, R4

Attachment A. Swagelok Manufacturing Locations

This document lists the Swagelok locations where end item or component level manufacturing activities take place.

Swagelok Company 29500 Solon Road Solon, Ohio 44139 USA	Swagelok Company (Falon 1) 348 Bishop Road Highland Heights, Ohio 44143 USA
Swagelok Company (Highland) 318 Bishop Road Highland Heights, Ohio 44143 USA	Swagelok Company (Falon 2) 358 Bishop Road Highland Heights, Ohio 44143 USA
Swagelok Company (OFC) 29495 F.A. Lennon Drive Solon, Ohio 44139 USA	Swagelok Company (HPF) 6050 Cochran Road Solon, Ohio 44139 USA
Swagelok Company (Atlantic) 26651 Curtiss Wright Parkway Willoughby Hills, Ohio 44092 USA	Swagelok Company (Snow Metal) 6060 Cochran Road Solon, Ohio 44139 USA
Swagelok Company (Micro) 26653 Curtiss Wright Parkway Willoughby Hills, Ohio 44092 USA	Swagelok Company (Alfred) 29500 Ambina Drive Solon, Ohio 44139
Swagelok Hose Services Company (SHSC) 29900 Solon Industrial Parkway Solon, Ohio 44139	Swagelok Company (Strongsville) 15400 Foltz Road Strongsville, Ohio 44119
Swagelok (China) Fluid System Technologies Ltd. Changshu Export Process Zone Changshu Economic Development Zone Changshu, Jiangshu 215513 China	Swagelok Company A.G. (European Technology Center) St. GallerstraBe 84 Lachen, Switzerland 8853 Switzerland
Swagelok Limited Ballafletcher Road Tromode IM4 4RA Isle of Man	

THIS IS PART OF
CRN 0C20862.5
Technical Standards & Safety Authority
Boilers & Pressure Vessels
Safety Program